

LUXURY APPLIANCES
FOR OUTDOOR LIVING

*Alfresco*TM

OPEN AIR CULINARY SYSTEMS



*Alfresco*TM



Made in the U.S.A. by Superior Equipment Solutions, Inc. • Commerce, CA
Toll-free (888) 383-8800 • (323) 722-7900 • fax (323) 726-4700
Visit our website at alfrescogrills.com • Email to info@alfrescogrills.com

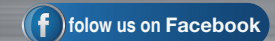

Imagine...

Your backyard transformed into your favorite resort getaway. Think of the time well spent with family and friends, the food, libations, and fun. It's no surprise that Alfresco can make your imagination reality - after all, we've designed and built equipment for many of the nation's finest hotels and restaurants. Through constant innovation, we strive to bring the professional culinary experience to the outdoors. Refrigerate, prep, cook, serve, and entertain with panache and style all with an Alfresco open air culinary system.

Alfresco[™]



The LX2 Intense Even Heat = Great Grilling



The key to perfectly grilled food is instant caramelization, which seals in juices for tender, moist and flavorful food. The LX2 grill has been engineered to deliver the intense, even heat needed to achieve perfect results, with the control and flexibility needed for all kinds of food.



Exclusive

18SR Stainless Steel w / Titanium main tube burners

27,500 BTU main burners are made from high-temp 18SR stainless steel and titanium with dual rows of double lanced combusting ports 3 sides plus a crossover tube for maximum surface flame distribution

- High temperature resistance - rated to nearly 3,500°F
- Oxidation and corrosion resistant for max longevity
- Unlike cast burners, delivers consistent, clean combustion
- Lifetime warranty

UNIQUE
18SR
STAINLESS

Exclusive

110 V Plug & Play Design Powers:

- Ignition
- Halogen Lighting
- Built-in Hidden Rotisserie Motor

Exclusive

Integrated, Hidden Rotisserie Motor w / Chain-driven Spit

- No need for counter balance weight
- Commercial motor with 120lbs of turning torque
- Oversized stainless steel rotisserie spit
- Ceramic infrared rear burner locks in juices and flavor

Cutaway of built-in rotis motor



Heat-stabilizing radiant briquette tray with rails to lock briquettes into place

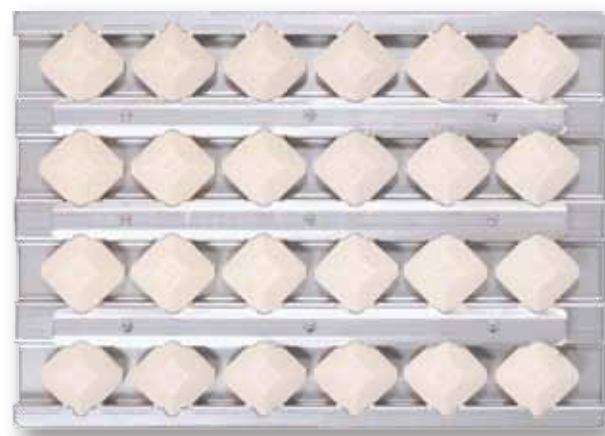

Porcelain ceramic 5-way heating briquettes

have a special pyramid shape and cavity back to collect and evenly distribute heat to the cooking surface. New radiant tray locks briquettes in place. Turn tray over and fire burners on high to self clean.



Exclusive

Rotisserie Spit Rod conveniently stores under bullnose when not in use



Made in the U.S.A. from all commercial-grade 304 18-8 stainless steel, all heli-arc welded by hand at all seams with no mechanical fasteners.



27,500 BTU Sear Zone™ is available on all LX2 grills. 100% combusting ceramic surface for intense even heat and authentic steakhouse results. Reaches 1,500° F in 4 minutes and cooks 50% faster with virtually no flare-ups

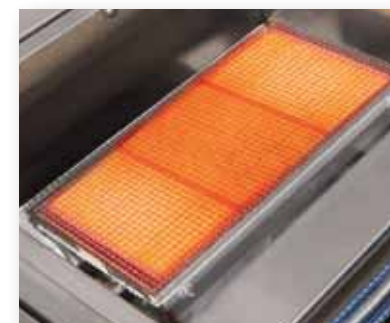

Full front and rear double skin, seamless, welded hoods with hand polished accents, featuring uniquely clean lines, with hidden hardware and no gap at the pivot point for the rotis spit. This results in a rigid and perfectly smooth pivoting hood that also captures more heat.



Integrated high-intensity halogen work lights angle slightly toward the center for bright, even illumination.

The LX2 Real Commercial Features

Integrated, Wood Smoker & Herb Infusion System

- dedicated 5,000 BTU s/s burner
- Exclusive
- cold smoke capabilities
- Wood drawer holds large wood chunks
- Linear defusing vents naturally ejects smoke at 200 degrees to food zone

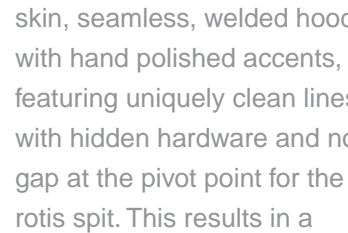

EXCLUSIVE
AIR COOLED
FRONT CONTROL
PANEL

NATURAL AIR COOLING DESIGN

Air Cooled Front Control Panel

Naturally provides a curtain of cool air that flows up through control panel protecting electronics and keeping all front surfaces safely cool



Standalone Sear Zone™

Optional on all grills (standard on 56" Jumbo models) is the Sear Zone™ ceramic infrared searing system. This 27,500 BTU ceramic burner heats to over 1,500 degrees in about 4 minutes and flash-caramelizes food locking in juices and flavor, while exclusive V-grate catches food drippings, instantly bursting natural flavors right back to food for optimal flavor enhancing.

56" Jumbo LX2 Grill



56" Deluxe LX2 Grill

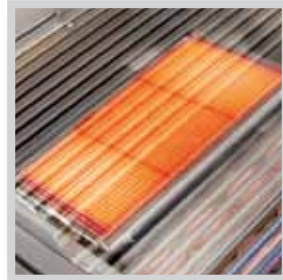

The Sear Zone™
Infrared system, an option on all other Alfresco grills, is a standard feature on the 56BFG.

Available Models

ALX2-56BFG
56" Jumbo built-in grill

ALX2-56BFGC
56" Jumbo cart model grill

ALX2-56BFGR
56" Jumbo on refrigerated cart



Cart model features dual storage drawers

NEW! Dual warming racks for added versatility

56" ALX2 ALL GRILL

- Three 18-SR stainless steel main burners producing 82,500 BTUs
- Sear Zone™ with 27,500 BTU ceramic infrared burner
- Integrated rotisserie system with built-in motor and dual 15,000 BTU infrared burners
- Smoker system with 5,000 BTU dedicated burner & drawer for wood chunk
- 998 sq. in. actual grilling area
- 3 Position warming racks stores up out of the way when rotissing
- Dual integrated high-intensity halogen work lights
- User-friendly push button ignition with sealed 110v AC power source

Alfresco's side burner accessories, such as a wok ring and commercial griddle all work with the 56" Deluxe LX2. grill.



Available Models

ALX2-56
56" Deluxe built-in grill With Sear Zone, ALX2-56SZ

ALX2-56C
56" Deluxe cart model grill With Sear Zone, ALX2-56SZC

ALX2-56RFG
56" Deluxe on refrigerated cart With Sear Zone, ALX2-56SZRFG



56" Grill also available w/ Integrated Refrigerated Base w/ Door & Two Marinating Drawers (see ARFG-42FB for refrigeration specs)

56" ALX2 DELUXE GRILL

- Three 18-SR stainless steel main burners producing 82,500 BTUs
- Integrated rotisserie system with built-in motor and 18,500 BTU infrared burner
- Smoker system with 5,000 BTU dedicated burner & drawer for wood chunks
- 770 sq. in. actual grilling area
- 3 Position warming racks stores up out of the way when rotissing
- Dual integrated 20,000 BTU side burner with recessed, sealed top and SS cover
- User-friendly push button ignition with sealed 110v AC power source
- Optional infrared Sear Zone™ and refrigerated base cabinet

42" LX2 Grill



The 42" LX2 is also available with 1 door and 2 drawer cart.

42" ALX2 GRILL

- Three 18-SR stainless steel main burners producing 82,500 BTUs
- Integrated rotisserie system with built-in motor and 18,500 BTU infrared burner
- Smoker system with 5,000 BTU dedicated burner & drawer for wood chunks
- 770 sq. in. actual grilling area
- 3 Position warming rack stores up out of the way when rotissing
- Dual integrated high-intensity halogen work lights
- User-friendly pushbutton ignition with sealed 110v AC power source
- Optional infrared Sear Zone™ and refrigerated base cabinet

Available Models

42" Built-in grill Model #ALX2-42 With Sear Zone, #ALX2-42SZ	42" Cart model grill w/ 2 doors Model #ALX2-42C With Sear Zone, #ALX2-42SZC	42" Cart model grill w/ 2 drawers Model #ALX2-42CD With Sear Zone, #ALX2-42SZCD	42" Cart model refrigerated grill Model #ALX2-42RFG With Sear Zone, #ALX2-42SZRFG
---	--	--	--

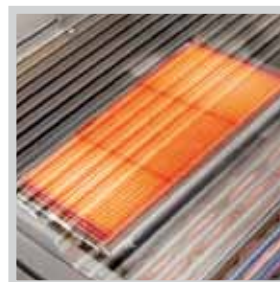

The Sear Zone™

infrared burner preheats to 1,500°F in about 4 minutes and cooks 50% faster, sealing in juices with virtually no flare-ups.



All LX2 grills feature an adjustable warming rack which stores up out of the way, allowing use of the rotis without removing the rack.



Insulated Jacket

If your enclosure is to be built of combustible materials, then an insulated jacket is required for safe installation of your grill. Order model #AIJ plus the size of the grill

36" LX2 Grill



The 36" LX2 is also available with 2 door cart

36" ALX2 GRILL

- Three 18-SR stainless steel main burners producing 82,500 BTUs
- Integrated rotisserie system with built-in motor and 18,500 BTU infrared burner
- Smoker system with 5,000 BTU dedicated burner & drawer for wood chunks
- 660 sq. in. actual grilling area
- 3 Position warming rack stores up out of the way when rotissing
- Dual integrated high-intensity halogen work lights
- User-friendly pushbutton ignition with sealed 110v AC power source
- Optional infrared Sear Zone™

Available Models

36" Built-in grill Model #ALX2-36 With Sear Zone, #ALX2-36SZ	36" Cart model grill Model #ALX2-36C With Sear Zone, #ALX2-36SZC	36" Cart w/2 drawer model grill (shown) Model #ALX2-36CD With Sear Zone, #ALX2-36SZCD
---	---	--

30" LX2 Grill



The 30" LX2 is also available with 1 door & 2 drawer cart

30" ALX2 GRILL

- Two 18-SR stainless steel main burners producing 55,000 BTUs
- Integrated rotisserie system with built-in motor and 15,000 BTU infrared burner
- Smoker system with 5,000 BTU dedicated burner & drawer for wood chunks
- 542 sq. in. actual grilling area
- 3 Position warming rack stores up out of the way when rotissing
- Dual integrated high-intensity halogen work lights
- User-friendly pushbutton ignition with sealed 110v AC power source
- Optional infrared Sear Zone™

Available Models

30" Built-in grill Model #ALX2-30 With Sear Zone, #ALX2-30SZ All infrared, #ALX2-30IR	30" Cart model grill Model #ALX2-30C With Sear Zone, #ALX2-30SZC All infrared, #ALX2-30IRC	30" Cart w/drawer model grill Model #ALX2-30CD With Sear Zone, #ALX2-30SZCD All infrared, #ALX2-30IRCD
--	---	---



Alfresco offers the industry's largest selection of transforming grill options.



Indirect Roasting Pod

Creates additional air gap between food and heat for slow roasting and conveniently holds drip pan for easy clean-up and basting. Uses adjacent burner for true indirect roasting.

Fits any Alfresco grill except the ALX2-36. #AIC-POD



Steamer / Fryer / Pasta

Drops into any Alfresco grill to blanch, steam, fry or boil. All s/s. Model #AG-SF



Standalone Sear Zone™

Our ceramic infrared searing burner in a convenient, self-contained unit. Built-in model #AGSZ



Food Warmer / Steam Table

Features 3 removable stainless steel food pans with covers, and a slide-out drawer for Sterno-type fuel canisters. Built-in model #AFW
Cart model #AFWC



Wok and Wok Ring

Commercial wok and ring, for use on the side burner or on the grill. Professional Wok #AG-WOK
Ring #AG-WR



Commercial Griddle

3/16" solid stainless steel plate with side and back splash, great for teppan, fajitas, breakfast or juicy burgers. for side burner #AGSB-G
for grill #AGSQ-G



Insulated Jacket

If your enclosure is to be built of combustible materials, then an insulated jacket is required for safe installation of your grill. Order model #AIJ
plus the size of the grill



Every year, in conjunction with the International Builder's Show, a showcase home is constructed to highlight the latest in green building technology, techniques and design. For the second time, Alfresco was chosen to design and equip the outdoor kitchen for the New American Home project.

The swim up bar featured a 42" LX2 grill with sear zone installed over a 42" under-grill refrigerator. Flanking the grill on the left is a 7.25 cu. ft. refrigerator with keggerator option, and on the right a trash center and 14" bartender.

For more info, visit www.builderonline.com



Versa Power

The Power of Versatility at Your Fingertips



Exclusive
Alfresco's new Versa Power™ cooker offers 400 to 65,000 BTUs of power for total heat control. The unique, specially designed super heavy-duty spider grate can handle from smallest of saucepans, and up to a 100 quart stock pot. With numerous options to expand its versatility, is the perfect complementary appliance to complete your outdoor kitchen.

Versa Power Cooking System Model #AGVPC

- Unique individually controlled double burner system
- Brass center burner adjusts from 400 to 20,000 BTUs
- S/S outer tube burner adjusts from 5000 to 45,000 BTUs
- 5/16" Diameter S/S spider grate w/ removable trivet



Burners uniquely high in burner box for flame to cookware contact

“The most versatile
Cooking
system period”

Ideal for use as
European French Top



from simmering delicate sauces → to a powerful low country boiler



Simmer delicate sauces at a low 400 BTU



Center burner adjusts from 400 to 20,000 BTU



Outer burner adjusts from 5,000 to 45,000 BTU



Both burners yield an unprecedented 65,000 BTU



Pot Filler #AGVPC-T10

Install into island next to Versa Power for convenient filling of large pots. Tower adjustable from 10 to 14" H. with double joint spout #POT-FAUCET

Side Burner

Restaurant Power & Control

Gives you commercial kitchen range performance in your outdoor kitchen



Teppanyaki Griddle & More Model #AGVPC-TG

3/16" solid stainless steel plate with back and end splashes. Ideal for multiple cooking styles. Great for Japanese Teppanyaki cooking, breakfast griddling, Mexican grill, Kamal Tortilla Cooking, and even works well as a plate warmer to keep those steaks sizzling when served.



Dual Side Burner

All commercial stainless steel with heli-arc welded seams, featuring two 20,000 BTU burners with electronic ignition. Recessed top and s/s cover for protection from wind and elements.

Available as built-in unit or mounts to cart model grills in place of side tray.
Cart model #AGSB-2C (hangs on grill cart)



Commercial Griddle

3/16" solid stainless steel plate with side and back splash, great for teppan, fajitas, breakfast or juicy burgers.
for side burner #AGSB-G



Commercial Wok Model #AGVPC-WOK

Remove the center ring grate from the Versa Power and drop in a true commercial round bottom wok. 21.5" dia. #AGVPC-WOK



Wok and Wok Ring

Commercial wok and ring, for use on the side burner or on the grill.
Professional Wok #AG-WOK
Ring #AG-WR

Refrigeration

Real all-weather performance



Alfresco is proud to have been the first company to introduce a real all-weather refrigerator that works even in extreme high temperatures.

Exclusive 7.25 Cu. Ft. Under Grill Refrigerator

Restaurant inspired design offers good ergonomics and versatility available integrated to 42 and 56" cart model grills. Built-in base only model #ARFG-42FB



- Door section with adjustable s/s wire shelf
- 2 Marinating drawers each with removable NSF food pan

Exclusive Features=Exceptional Unprecedented Outdoor Performance

- All stainless steel construction inside & out
- 1000 BTU all-weather refrigeration system for deep cooling
- Certified to **NSF** standards (National Sanitation Foundation)
- Temperatures uniquely adjustable from 27 to 56 degrees F
- Commercial fan-driven fin evaporator cooling inside
- Fully front breathing
- Commercial polyurethane shot-in-place foam insulation
- Flash Recovery System quickly cools internal temperature
- User-friendly digital control with lighted display
- Door-activated internal lighting

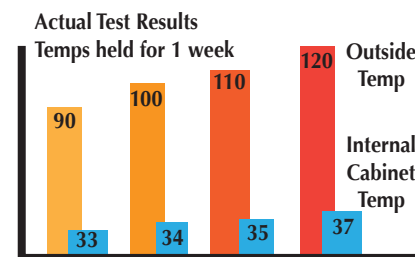

Only our refrigerators can maintain extremely cold internal temperatures in very hot outside temperatures. (results may vary due to conditions)

7.25 cu. ft. One Door Refrigerator



Exclusive

- Digital control with lighted display
- Commercial fan driven fin coil cooling
- horizontal vortex of air

Model # URS-1

- 2 Removable adjustable s/s wire shelves
- Field reversible doors
- Converts to keggerator in seconds Optional keg kit - #AKK
- Freestanding refrigerator Optional caster assembly #ACK

Exclusive Converts Easily to Keggerator

Alfresco-built keg dispensing tower uniquely inserts into rear of refrigerator leaving top center free of obstruction.

#AKK Beer dispensing kit includes:

- Alfresco built stainless steel tower w/ faucet
- CO2 tank
- beer lines w/ quick disconnect
- Pressure gauges
- Drip tray w/ anti-splash grate



Refrigeration

Real all-weather performance

Exclusive

Versa Chill Counter top Refrigerator

Real commercial top access cooler features: state-of-the-art frost wall cooling technology. Temperature range adjusts from the low teens to 56°F.

Built-in model #ARDI Freestanding Cart model ARDI-C



No limitations!

- Bottle Cooler
- Mug Froster
- Martini freezer
- Fresh fruit smoothie and juice center
- Deli-prep center
- Burger topping/condiment bar
- Salsa bar
- Bottle/Ice Bath
- Wine Cooler
- Keggerator
- Desert Bar

Standard features Include:

- 1,200 BTU all-weather refrigeration system
- Insulated tilt-up and removable stainless steel cover
- Commercial polyurethane shot-in-place foam insulation
- Three removable NSF food pans
- slideable intermediate stainless steel wire shelf
- 1-inch brass drain for easy clean-up
- 101 lb Ice Capacity

Add a built-in unit to your island for super convenient cold storage.

cold pans for perishable condiments.

Thermostat-controlled temperature from the teens to 56°.

Half-width mid-depth for access to lower level.

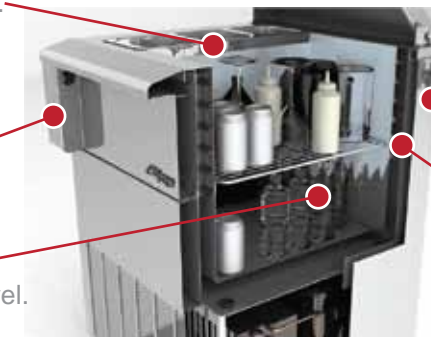

Exclusive

Commercial frost wall technology.

Frost wall creates an arctic blanket of frigid cold air

Cutaway view showing the frost wall design



Libation, Smoothie & Juice Bar



All provision & glass chiller



Ice/Bottle Bath



Keggerator



Electric Warming Drawer

30" wide drawer with electronic temp. control. Includes four convenient removable s/s food pans each with removable s/s lid. Model #AWD-30



Exclusive

Sealed Dry Storage Pantry

Store dry goods, cookware, and more in a completely sealed environment, safe from weather and pests. 4 sizes with interior drawers and shelf. Model #ADSP-30 or 42 plus H or L for high or low



Sealed pantries feature drawers & adjustable shelves



Magnetic rubber gasketed doors for a tight seal



30" Pantries

Low Profile: Model #ADSP-30L
High Profile: Model #ADSP-30H

Exclusive sealed dry storage pantries protect dry provisions, tools, and cookware from weather and pests



42" Pantries

Low Profile: Model #ADSP-42L
High Profile: Model #ADSP-42H

Exclusive

Plating and Garnish Center

Restaurant inspired plating station w/ food pans, carving board and plate storage below. Create food presentations like a professional. Model #APS-30P



Optional package makes a perfect pizza prep table



Prep and Hand Wash Sink

All s/s design with hot & cold faucet, removable cutting board and C-fold towel dispenser. Model #ASK-T

17" Single Access Door

Left Door, #AB-17L
Right Door, #AB-17R



23" Single Access Door

Left Door, #AB-23L
Right Door, #AB-23R



Double Access Doors

30" Wide Doors, #AB-30
36" Wide Doors, #AB-36
42" Wide Doors, #AB-42



30" Storage Drawer

Oversize for large pans. Model #AB-30DR



Paper Towel Holder

For standard roll towels. Model #AB-TH



Doors feature multiple mounting options and internal storage rail



Drawers pull out on German engineered smooth gliding full extension slides



Accessory Speed Rails

14" Wide Rail, #RAIL-14
19" Wide Rail, #RAIL-19



32" Combo Door & Drawers

Door on left, #AB-DDC-L
on right, #AB-DDC-R



Storage Drawers

2 Drawer Unit, #AB-2DR
3 Drawer Unit, #AB-3DR



Trash Center Drawer

Single bin, #AB-TC
Double bin, #AB-TC2
Includes durable plastic receptacle(s).



Prep & Waste Chute

Sliding poly cutting board covers trash chute. Model #APWC



Beverage Centers & Versa Sinks



NEW
Sensible Under-the-counter Solution
Exclusive
Model AB-ID

Undercounter-Ice drawer & Beverage Center “save valuable counter space”

All stainless steel construction
 Heavy duty 150LB capacity drawer slides
 Fully insulated housing & drawer face

Standard Components Include:
 NSF s/s pan 6-inches deep holds 32 LBS of ice
 4 condiment pans
 bottle & glass storage

Remove components and use as large ice drawer



1" Foam insulation
 Magnetic rubber gasket



Exclusive
AGBC-14 Versa Sink
 Sink Basin Size 11" w X 21" d X 8 1/4" h
 3" basket drain w/ stopper
 Full ice capacity 32 lbs
 1" foam insulation all sides & bottom



Faucet not included

AS SINK



AS BEVERAGE CENTER

- Each Includes convenient accessories:**
- separate s/s ice pan for sink and ice combo use
 - hang-on front bottle speed rail (3) bottle capacity
 - sliding s/s cover

Exclusive
AGBC-24 Versa Sink
 Sink Basin Size 19" w X 21" d X 8 1/4" h
 3" basket drain w/ stopper accommodates disposer
 Full ice capacity 60 lbs
 1" foam insulation all sides & bottom



Faucet not included



AS BEVERAGE CENTER

Versa Sink System Prep and Serve in Style

Exclusive
AGBC-30 Versa Sink
 Sink Basin Size 27" w X 21" d X 8 1/4" h
 3" basket drain w/ stopper accommodates disposer
 Full ice capacity 32 lbs
 1" foam insulation all sides & bottom
 wood cutting board



Faucet not included

30" Main Sink



Wood Cutting Board Standard w/ Main Sink

Towel Holder
 Simple bar for hand towels.
 Model #TH

Speed Rail
 Holds bottles for easy access.
 Comes in two sizes.
 Model #SPR-LG or #SPR-SM



High Shelf w/Pot Rack & Light
 Tru-commercial prep.
 Model #PR-30

Middle Shelf
 Model #MS



4" Deep Stainless Colander
 For easy draining.
 Model #COLANDER

Alfresco's modular system allows you to customize the basic unit to suit your exact needs and entertaining style. All the accessories shown can be quickly attached to the main sink without tools so you can re-configure at any time.



Serving Shelf w/Light
 Model #HS-30

Condiment Tray
 Keep small items accessible.
 Model #CT



6" Deep Stainless Ice Pan
 Slides on sink rails.
 Model #ICE PAN



Bottle Wells
 4 wells with tray.
 Model #BWELL

Blender Shelf
 Tru-commercial design.
 Model #BS

As Beverage Center

Speed Rail
 Holds bottles for easy access.
 Comes in two sizes.
 Model #SPR-LG or #SPR-SM

Bottle Opener / Towel Rack
 Includes cap catcher.
 Model #BO



Front accessories easily attach on and off for quick reconfiguration of the sink



“Let Alfresco’s professional kitchen design team help make your outdoor dream kitchen become a reality”



How it works:

Just provide your local authorized Alfresco dealer with basic information of the outdoor space where you will be planning your outdoor kitchen, and Alfresco's commercial kitchen design experts will provide a design that would make any professional chef feel right at home.

Provide your authorized Alfresco dealer with the following:

- Simple sketch (see sample sketch) of the space w/ lines and dimensions
- Direction indicator i.e. East, West, North, South
- Location of house in relationship to kitchen
- Location of pool (if one) in relationship to kitchen
- Outdoor room (if one) in relationship to kitchen
- Outdoor Fireplace if one
- Prevailing wind direction in relationship to kitchen
- View in relationship to kitchen
- Photos of space if possible
- Gas type i.e. natural or propane

You Provide This, & We will Provide →

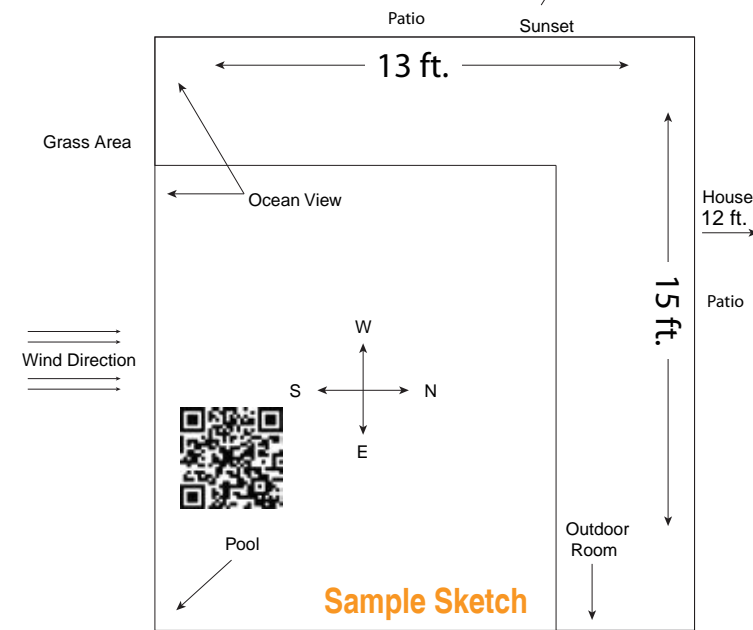

Sample Sketch

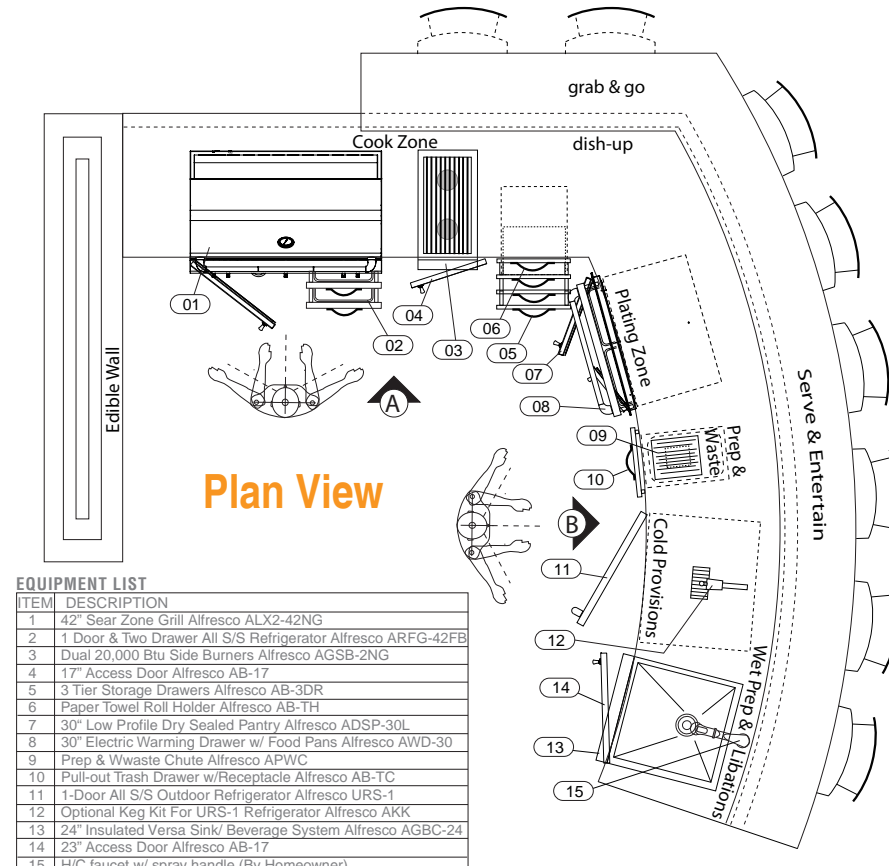

Plan View

ITEM	DESCRIPTION
1	42" Sear Zone Grill Alfresco ALX2-42NG
2	1 Door & Two Drawer All S/S Refrigerator Alfresco ARFG-42FB
3	Dual 20,000 Btu Side Burners Alfresco AGSB-2NG
4	17" Access Door Alfresco AB-17
5	3 Tier Storage Drawers Alfresco AB-3DR
6	Paper Towel Roll Holder Alfresco AB-TH
7	30" Low Profile Dry Sealed Pantry Alfresco ADSP-30L
8	30" Electric Warming Drawer w/ Food Pans Alfresco AWD-30
9	Prep & Wwaste Chute Alfresco APWC
10	Pull-out Trash Drawer w/Receptacle Alfresco AB-TC
11	1-Door All S/S Outdoor Refrigerator Alfresco URS-1
12	Optional Keg Kit For URS-1 Refrigerator Alfresco AKK
13	24" Insulated Versa Sink/ Beverage System Alfresco AGBC-24
14	23" Access Door Alfresco AB-17
15	H/C faucet w/ spray handle (By Homeowner)

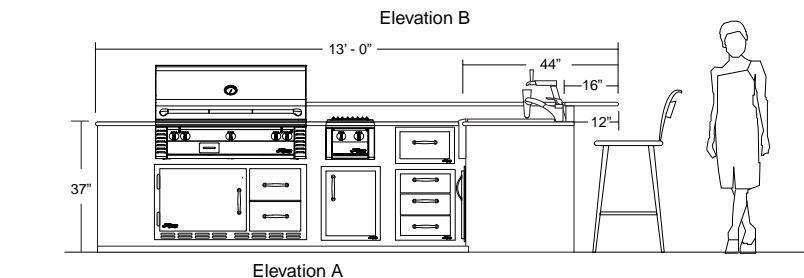
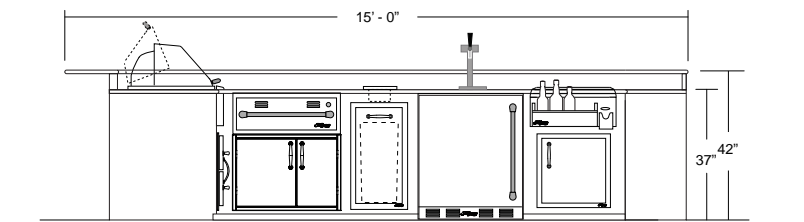

Elevation A

Tips for Designing the Perfect Outdoor Kitchen

When designing commercial kitchens, the layout is broken into “zones,” and the location of each zone is strategically placed in order to create harmony in the operation to maximize efficiency. It’s also important that each zone is ergonomically intuitive, having all the essential components confined to the zone, keeping everything in arms reach from point of stance. Alfresco has designed all of the pieces necessary to create a fully-functional outdoor kitchen - one in which any professional chef would feel right at home.

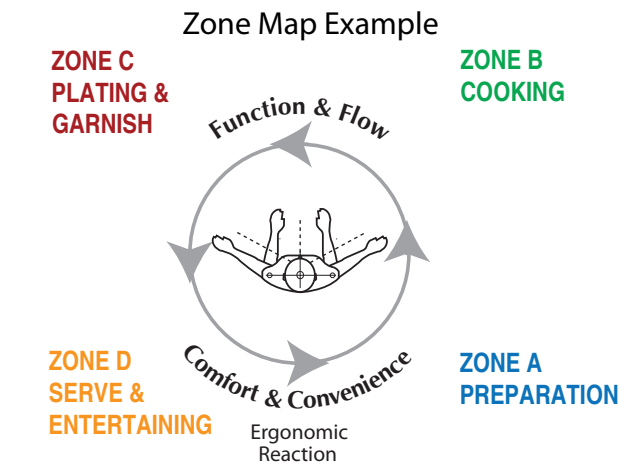

Things to Consider When Planning

- The ideal location for your outdoor kitchen
- Number of guests you would entertain on a normal basis
- Are utilities available at the location e.g. water, gas, elec, etc.
- Orientation of outdoor kitchen to house, view, outdoor room, pool
- Orientation to sunset. (be sure seating doesn't face West)
- Prevailing wind direction (avoid positioning grill with backside to wind)
- Seating should not be positioned at backside of grill
- Island enclosure material (insulated jacket required for combustible)
- Refrigeration, sealed dry storage, & large sink eliminate trips in and out
- Let Alfresco's Design Solutions professionals assist in your design
- Remember, your Alfresco dealer is a great source for ideas and knowledge, and creating your dream Alfresco kitchen.

Installation & Cutouts

Complete the Dream Kitchen



Grills & Insulated jackets

MODEL	CUTOUT DIMENSIONS			NOTCH N	✓	POWER			GAS LINE
	W	D	H			YES	NO	AMPS	
ALX2 / AGBQ-30	28-1/2"	23"	10-1/4"	7/8"	✓		1.44 / 0.91	✓	
ALX2-36	34-1/2"	23"	10-1/4"	7/8"	✓		1.44 / 0.91	✓	
ALX2 / AGBQ-42	40-1/2"	23"	10-1/4"	7/8"	✓		1.44 / 0.91	✓	
ALX2 / AGBQ-56	54-1/2"	23"	10-1/4"	7/8"	✓		1.44 / 0.91	✓	
AIJ-30	33-1/4"	24-5/8"	11-1/4"	7/8"	✓	◆		✓	
AIJ-36	39-1/4"	24-5/8"	11-1/4"	7/8"	✓	◆		✓	
AIJ-42	45-1/4"	24-5/8"	11-1/4"	7/8"	✓	◆		✓	
AIJ-56	59-1/4"	24-5/8"	11-1/4"	7/8"	✓	◆		✓	

Note 1: All Grills Require a 1/2" NPT Gas Connection with 4" WC for natural gas and 10" Wc for liquid propane.

Note 2: All power supplies are 115 VAC-1ø-60 Hz. GFCI Receptacle recommended.

◆ Note : Power Requirement as stated on the corresponding grill (NOT DUE TO THE AIJ JACKET BY ITSELF).

Dimensions and specifications are subject to change without notice. Please visit our website for the latest updates.

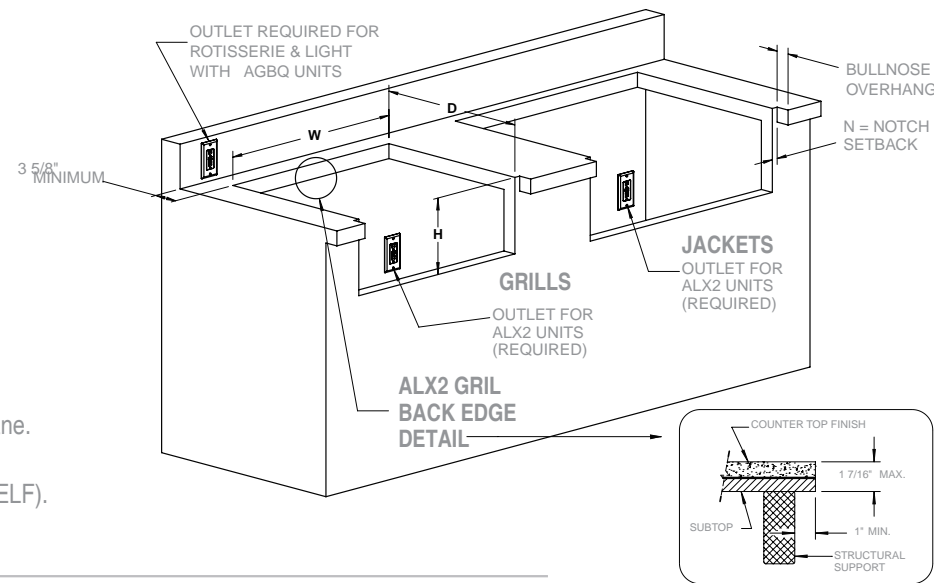

Countertop Accessories

Accessories

MODEL	CUTOUT DIMENSIONS			NOTCH N	SETBACK S	✓	POWER			GAS LINE	WATER LINE	DRAIN LINE
	W	D	H				YES	NO	AMPS			
AGVPC	21-1/2"	22-1/2"	10-1/4"	1-3/8"			✓		✓			
AGVPC-T10	4-1/2"	4-1/2"			1-5/8" ◆		✓			3/8" ✪		
AGSB / AGSZ	13-1/4"	23"	10-1/4"	1/2"			✓		✓			
AFW	13-1/4"	23"	10-1/4"	1/2"			✓					
ADT-14	13-1/4"	23"	9-1/4"	1/2"			✓			1/2"	1"	
ADT-24	23-1/4"	23"	10-1/4"	1/2"			✓					
ADT-30	28-1/2"	23"	10-1/4"	3/4"			✓			1/2"	1" + 2"	
AGBC-14	13-1/4"	23"	9-1/4"	1/2"			✓			1/2"	1"	
AGBC-24	23-1/4"	23"	10-1/4"	1/2"			✓				1"	
AGBC-30	28-1/2"	23"	10-1/4"	7/8"		✓		0.08			1-1/2"	
ASK-T	13-1/4"	23"	10-1/4"	1/2"			✓			1/2"	1"	
APS-30	27-1/2"	8-3/4"	9-1/4"	1-3/8"			✓					
APS-30P	27-1/2"	15-1/4"	9-1/4"	1-3/8"			✓					

Note 1: All Burners Require a 1/2" NPT Gas Connection with 4" WC for a natural gas and 10" Wc for liquid propane.

Note 2: All Water Lines are 1/8" compression or 1/2" NPSN unless otherwise shown.

Note 3: All Drains sizes as shown are NPSM standard.

Note 4: All power supplies are 115 VAC-1ø-60 Hz. GFCI Receptacle recommended.

◆ Note : The AGVPC-T 10 pot Filler Tower requires a minimum setback as shown (OVER AND UNDER THE COUNTER) from the back wall for proper hardware installation.

✪ Note : The AGVPC-T 10 pot Filler Tower requires a 3/8" compression water line and comes with a 72" Long copper line for field connection.

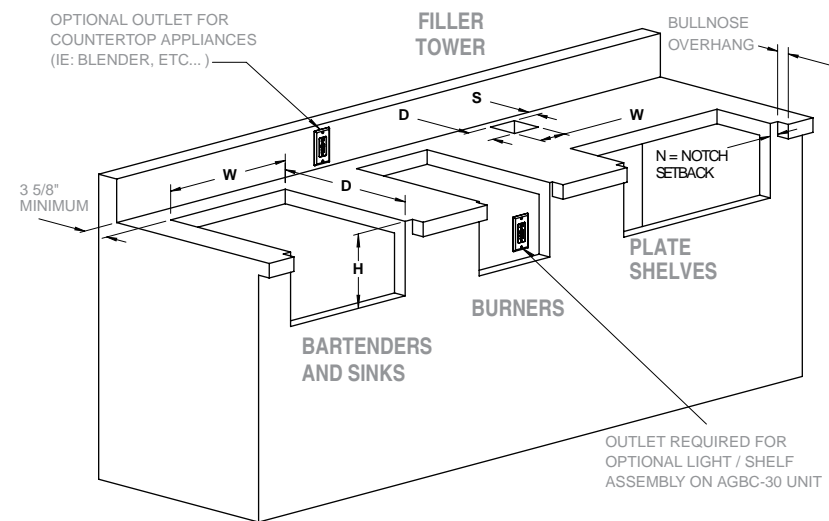

Front Mounted Island Accessories, Pantries, Doors, Drawers and Combo Units

MODEL	CUTOUT DIMENSIONS				SETBACK S	POWER			DRAIN LINE
	W	H	D	L		YES	NO	AMPS	
AB-17L / AB-17R	13-7/8"	18-1/2"	~			✓			
AB-23L / AB-23R	19-7/8"	18-1/2"	~			✓			
AB-30	27-1/4"	18-1/2"	~			✓			
AB-42	39-1/4"	18-1/2"	~			✓			
AB-DDC-L / AB-DDC-R	29-1/4"	18-1/2"	19-1/4"			✓			
AB-2DR	14-3/4"	12-1/2"	19-1/4"			✓			
AB-3DR	14-3/4"	19-1/4"	19-1/4"			✓			
AB-30DR	27-3/4"	14"	23-3/4"			✓			
AB-ID	24"	17-3/4"	25-1/8"			✓		5/8" ✪	
AB-TC (TRASH ONLY)	12-1/2"	26-1/2"	18-1/2"			✓			
AB-TH	14-1/2"	8-1/2"	7-7/8"			✓			
ADSP-30H	28-3/8"	31-3/4"	23-3/8"			✓			
ADSP-30L	28-3/8"	19-3/8"	23-3/8"			✓			
ADSP-42H	40-3/8"	31-3/4"	23-3/8"			✓			
ADSP-42L	40-3/8"	19-3/8"	23-3/8"			✓			
APWC (CHUTE ONLY)	6-1/4"	~	~	8-1/4"	4-5/8" ◆	✓			
AWD-30	28-1/2"	10"	20-1/4"			✓		3.9	

Note: All power supplies are 115 VAC-1ø-60 Hz. GFCI Receptacle recommended.

◆ Note: 4-5/8" Setback required from cabinet face (NOT BULLNOSE!).

✪ Note: AB-ID unit comes with 36" plastic drain hose for condensate / ice water waste.

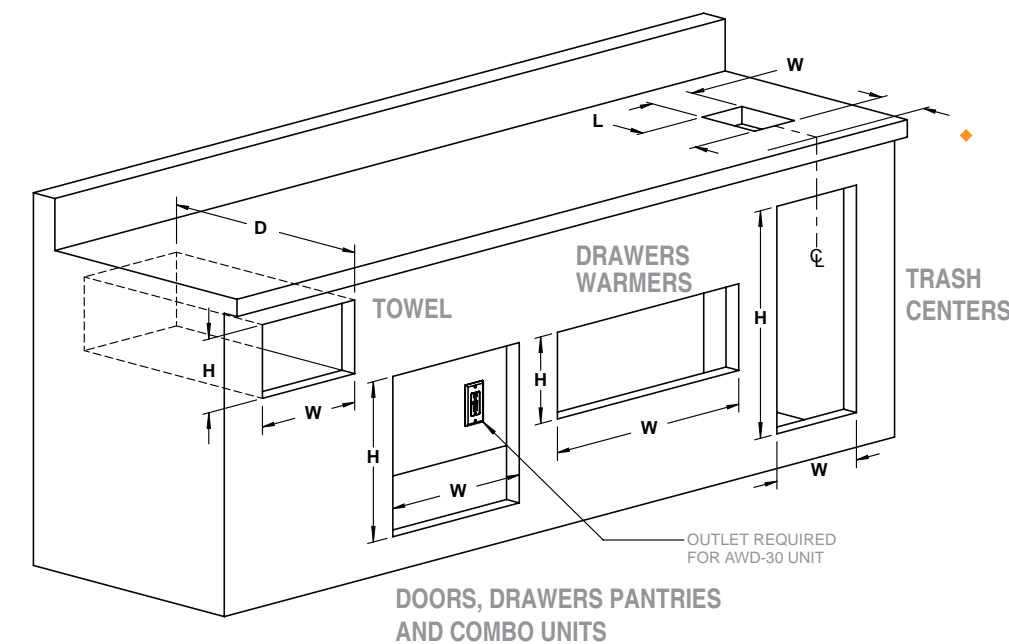

Refrigerator

MODEL	DIMENSIONS			NOTCH N	SETBACK S	POWER			DRAIN LINE
	W	H	D			YES	NO	AMPS	
AKK	2" DIAMETER HOLE				21-15/16" ◆	✓			
ARDI	23"	32"	23"	13/16"		✓		5.7 1" ✪	
ARFG-42FB	42-1/2"	21-3/4"	23-1/4"		2" ◆	✓		2.9	
URS-1	28-1/2"	35"	23-3/8"			✓		2.8	

Note: All power supplies are 115 VAC-1ø-60 Hz. GFCI Receptacle recommended.

◆ Note: Setback measured from cabinet front (NOT BULLNOSE!).

✪ Note: Drain size is NPSM-floor drain in lieu of wall mount is acceptable.

◆ Note: Setback minimum distance from floor to accommodate ARFG-42 perimeter flange.

